

A 图面新发行 2011-08-15 Jine OSCAR
 B 添加塑料直径 2013-10-17 Oscar

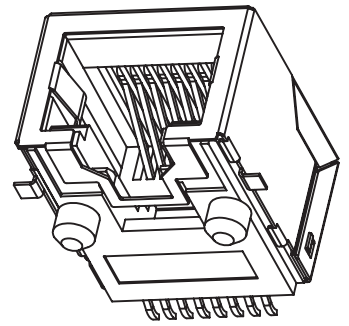
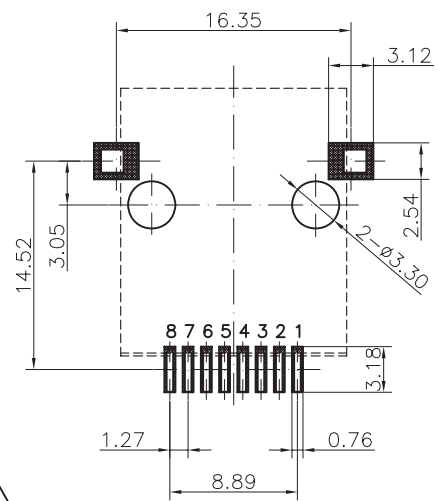
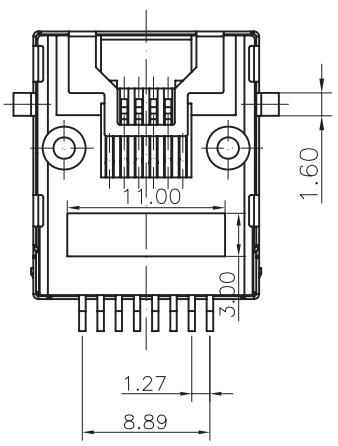
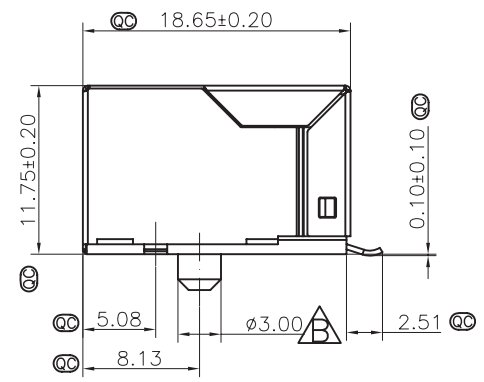
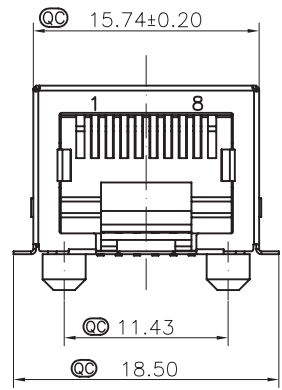

NOTES:

ELECTRICAL:

- VOLTAGE RATING : 125 VAC RMS.
- CURRENT RATING : 1.5 AMP.
- CONTACT RESISTANCE : 50 MILLIOHMS MAX.
- INSULATION RESISTANCE: 500 MEGOHMS MIN @ 500 VDC.
- DIELECTRIC STRENGTH : 500 VAC RMS 50Hz, 1MIN.

MECHANICAL:

- HOUSING MATERIAL : NYLON(PA46)+30%.G.F UL94V-0.
- CONTACT MATERIAL : PHOSPHOR BRONZE T=0.35mm (C5210)
- PLATING : GOLD-PLATED IN THE CONTACT AREA
- SHIELD: COPPER ALLOY(OR STEEL ALLOY) 0.20mm THICKNESS
- OPERATING LIFE : 750 CYCLES MIN.
- PCB RETENTION PRE-SOLDER : 1 LB MIN.
- PCB RETENTION POST-SOLDER: 10 LBS MIN.

ENVIRONMENTAL:

- STORAGE : -40°C TO +85°C.
 - OPERATION: -40°C TO +85°C.
 - IR REFLOW PEAK SOLDERING TEMPERATURE:255°C~265°C 5~10 SECONDS.
 - ROHS COMPLIANT
- FCC PART 68, SUBPART F.
 MATES WITH MODULAR PLUG CONFORMING TO

料品编码: 84 0 5 - 2 8 8 3 1 X

84 SERIES:
 (SMT JACK)

- 产品规格:
- 01 -SMT H=11.5mm W=13.2 mm
 - 02 -SMT H=11.5mm W=12.30 mm
 - 03 -SMT H=11.65mm W=13.85mm
 - 04 -SMT 塑料
 - 05 -SMT H=11.75mm W=18.65mm
 - 06 -SMT H=11.50mm W=14.60mm

SHIELD:

- 1 - W/O SHIELD
 - 2 - 有屏蔽 3-无屏蔽
- Position
 6 - 6 POSITION 8 - 8 POSITION
 0 - 10 POSITION

CONTACTS:

- 4 - 4 CONTACTS 6 - 6 CONTACTS
- 8 - 8 CONTACTS 0 - 10 CONTACTS

- 塑料材料:
- 1 - Fu" 2-2u" 3-3u"
 - 4 -6u" 5-15u"
 - 6- 30u" 7-50u"
- LOGO& PCB TYPE
- 0 - W/O LOGO
 - 1 - W/HAXN LOGO
 - 2 - W/HAXN & UL LOGO
- Plastic Material& Color
- 1 - PBT+20%GF Black
 - 2 - NYLON46 Black
 - 3 - LCP Black

库乐科技